



WILLIAMS WALK

Rockbank • 3335

TOWNHOMES

CONTEMPORARY
LIVING
BY NOSTRA





Artist Impression

WELCOME TO CONTEMPORARY LIVING AT WILLIAMS WALK

TURN-KEY HOMES

4  2  2 

The next-generation of contemporary homes at Williams Walk, Rockbank aim to re-define the way you can live, setting a new benchmark in flexible, light-filled living environments.

As part of this vision, Nostra has partnered with Villawood Properties to bring you a selection of stunning 4 bedroom townhomes that provide a contemporary living solution perfect for first home buyers, downsizers, investors or someone looking for a low maintenance and modern lifestyle. These homes feature an enviable list of fixed price inclusions along with a timeless street appeal. Packed with style and convenience these homes impress from the outset with their easy living.

Put down roots in western Melbourne's newest neighbourhood – where community ties and urban vibes provide the perfect setting for a life well lived.

WILLIAMS WALK WALK THIS WAY

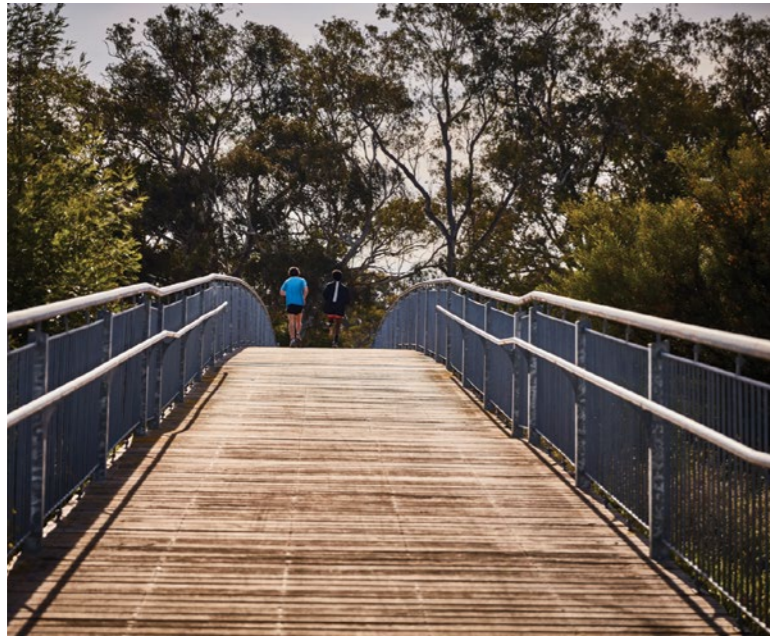

With two new Town Centres planned close by, the urban vibe is never far away. Yet neither is the beauty of nature, with some of the north west's premier natural attractions within easy reach, including Melton Botanic Gardens, Pinkerton Forest and the Werribee River. And with plenty of good primary schools, high schools and early education centres nearby, it's an ideal place for families.

Convenient and connected, Williams Walk combines all the elements of a great lifestyle.

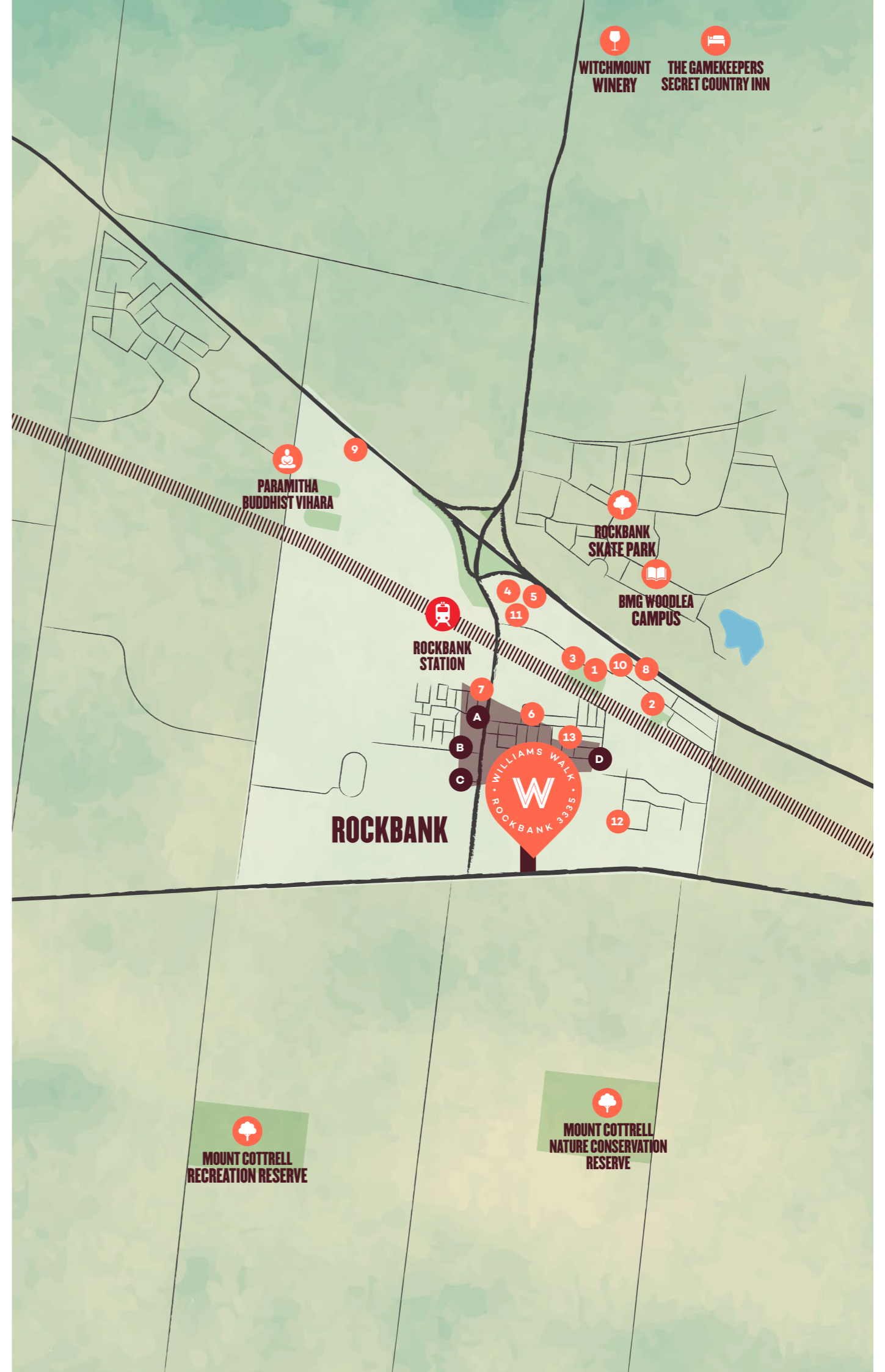

CONTEMPORARY LIVING SITE PLAN

The Nostra Contemporary Living release is located in a great location within Williams Walk.

A collection of 12 turn-key homes with a stunning street appeal awaits, walk this way.

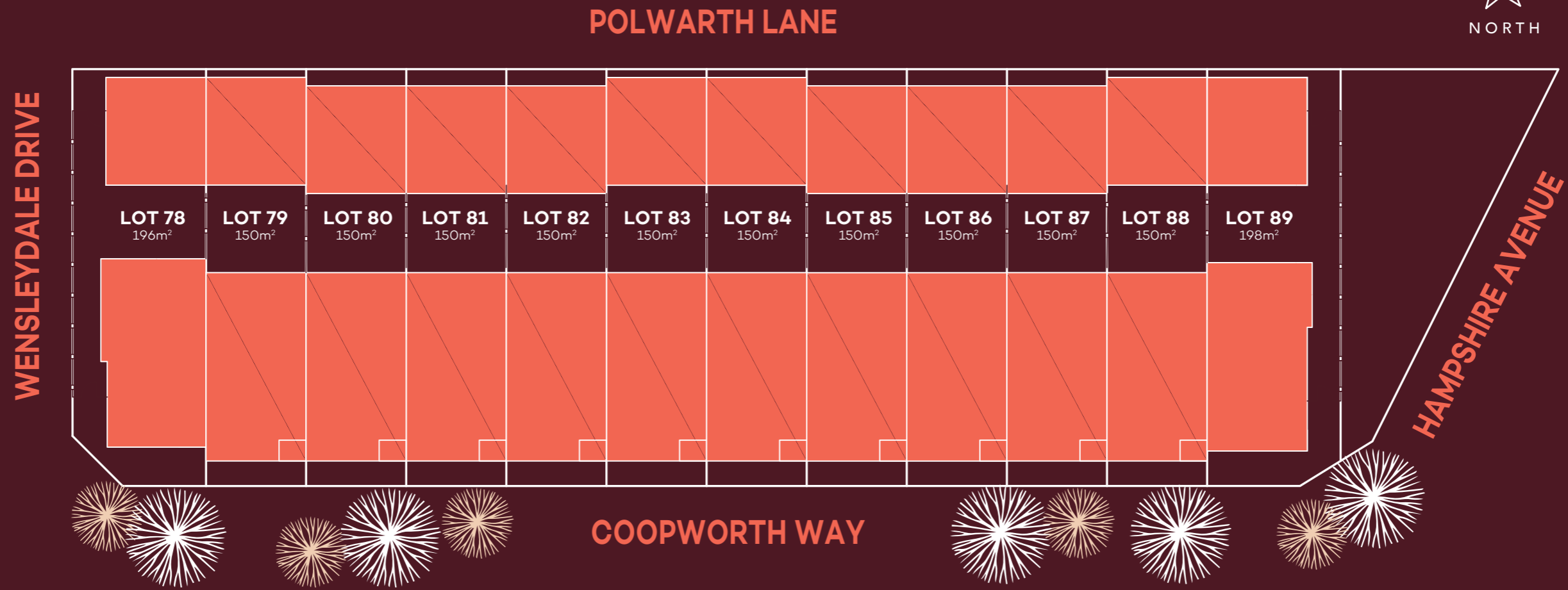

READY TO MOVE IN

CONTEMPORARY LIVING AT WILLIAMS WALK

CONTEMPORARY LIVING AT WILLIAMS WALK



Lot 79

Lot 81

Lot 83

Lot 85

Lot 87

Lot 89

Lot 78

Lot 80

Lot 82

Lot 484

Lot 86

Lot 88

Turn-key Inclusions

LED downlights to main living area

2590mm high ground floor ceilings

Low maintenance landscaping

Your choice of tiles or timber look floors and carpet throughout

Stainless steel ppliances including dishwasher

Three stunning colour schemes on offer

20mm stone to kitchen benchtops



AT WILLIAMS WALK, YOU DON'T NEED TO COMPROMISE. HERE YOU'LL FIND A CLOSE-KNIT COMMUNITY WITH EASY ACCESS TO EVERYTHING YOU NEED TO LIVE THE LIFE YOU DREAM OF.

CONTEMPORARY LIVING AT WILLIAMS WALK FLOOR PLANS

Floor plan variation | Lot 78

4 2 2

REFER TO INDIVIDUAL FLOOR PLANS

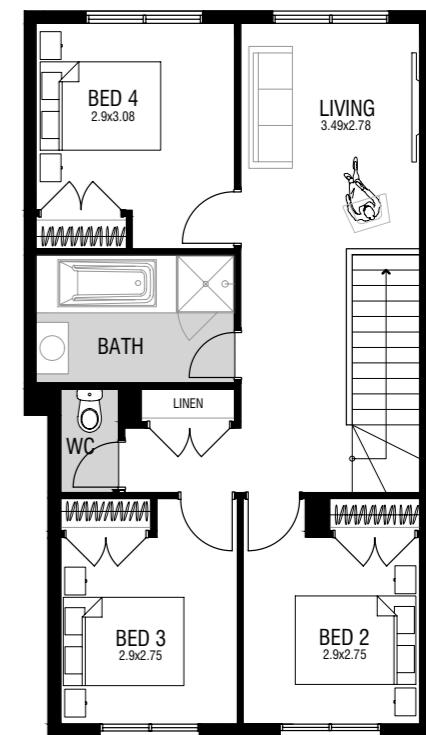
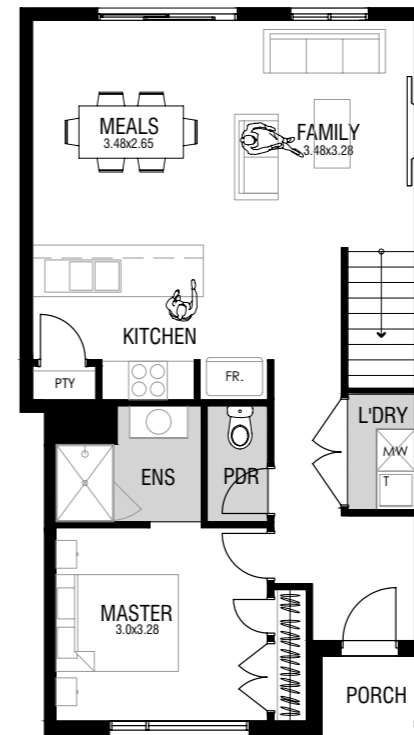
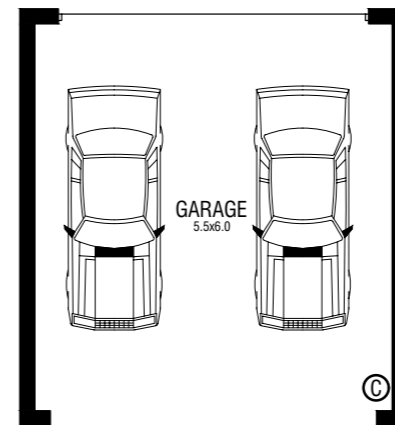

CONTEMPORARY LIVING AT WILLIAMS WALK FLOOR PLANS

Floor plan variation | Lot 79-88

4  2  2 

REFER TO INDIVIDUAL FLOOR PLANS

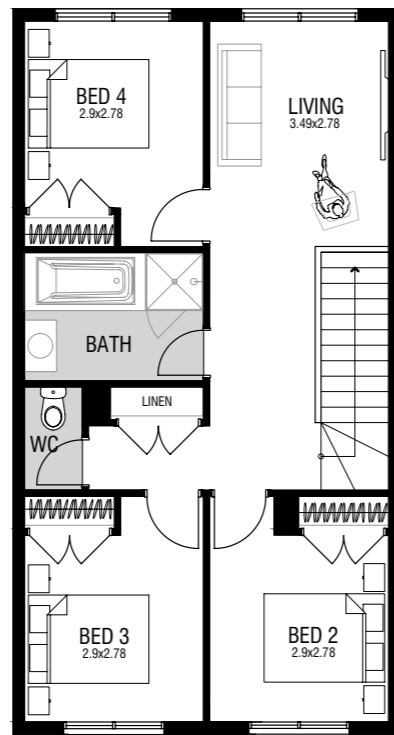
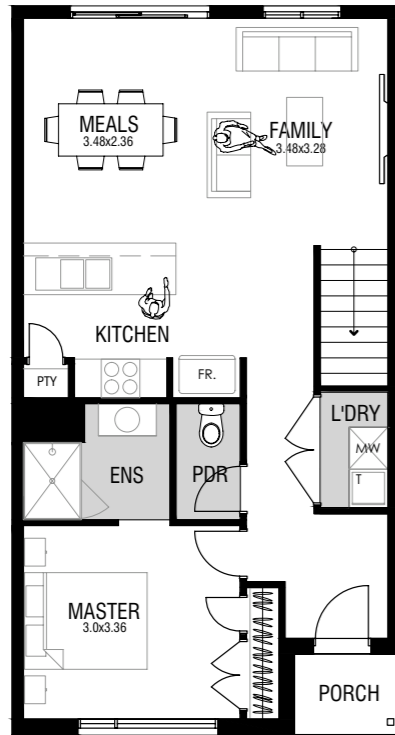
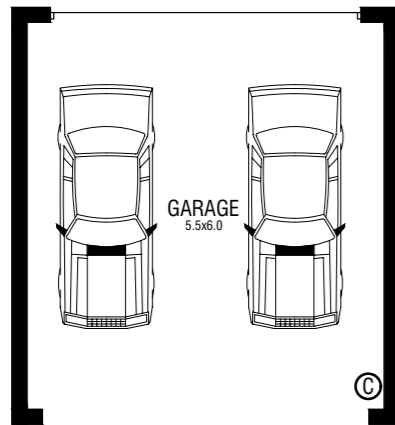

Floor plan variation | Lot 89

4  2  2 

REFER TO INDIVIDUAL FLOOR PLANS

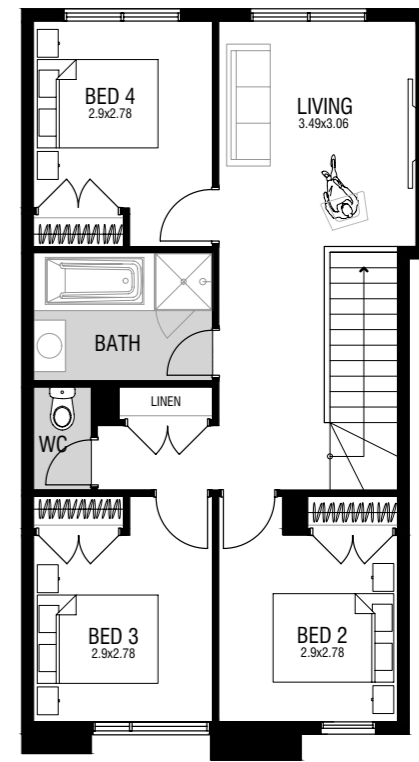
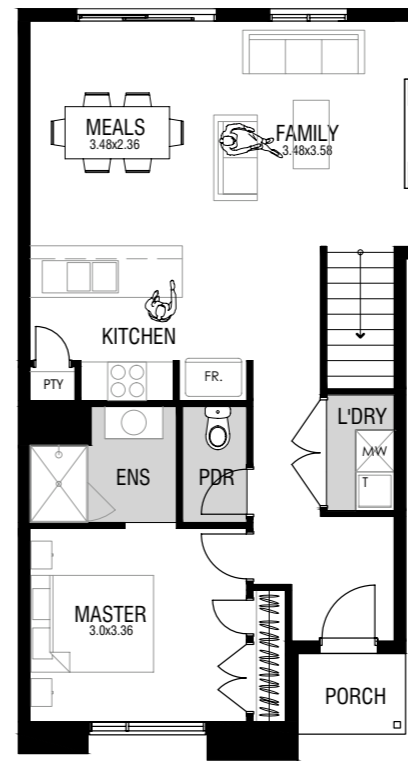
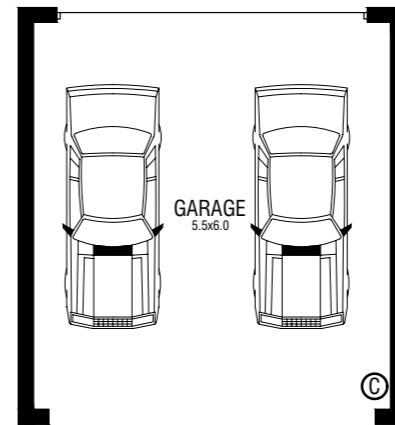

Your Standard Inclusions

GENERAL

- ▶ 25 year structural guarantee
- ▶ Dwelling constructed independently

CONNECTIONS

- ▶ Garden tap
- ▶ Stormwater drains
- ▶ Sewer drains
- ▶ Electricity, gas and water connections
- ▶ Fibre Optic provisions (does not include installation of Hub or final connections)
- ▶ All connections exclude consumer connection fees and utility account opening fees

FOUNDATIONS

- ▶ Fixed site costs (Includes rock and retaining walls)
- Note: Retaining walls are included for structural requirements only. Any retaining wall requirements for landscaping are not included.
- ▶ Engineered concrete slab

FRAMING

- ▶ Stabilised pine or steel wall frames
- ▶ Engineered designed roof trusses

CEILINGS

- ▶ 2590mm height for single storey and ground floor of double storey designs with 2400mm for upper levels
- ▶ 90mm cove cornice throughout

WINDOWS

- ▶ Aluminium windows
- ▶ Keyed Locks to all windows

FACADE

- ▶ Facade as noted in approved architectural drawings

EXTERNAL CLADDING

- ▶ VBA compliant cladding

ROOF PLUMBING/TILES

- ▶ Fascia, gutter, downpipes and cappings with concrete roof tiles
- Note: Certain designs are zinc flat deck specific

INSULATION/6 STAR

- ▶ Sisalation wall wrap
- ▶ Wall batts to external walls
- ▶ Insulation wool to ceiling cavity of living areas
- ▶ Gas solar hot water unit (note: when an estate requires recycled water connection, a gas continuous flow hot water unit will be supplied in lieu of a gas solar hot water unit)

GARAGE

- ▶ Panel lift Garage door

STAIRS

- ▶ MDF treads and risers with carpet (plan specific)

DOORS/FURNITURE

- ▶ Entry: 2040mm x 820mm Solid core door with Trilock entrance set
- ▶ Internal: 2040mm high Flush panel doors with Brushed Chrome passage handles and air cushioned door stops
- ▶ Chrome knob to robe cupboards

SKIRTING/ARCHITRAVES

- ▶ 67mm x 18mm Primed MDF skirting and architraves
- ▶ Tiled Skirting 100mm to wet areas

SHELVING

- ▶ Robes: x 1 shelf with chrome hanging rails
- ▶ Pantry: x 4 shelves
- ▶ Linen: x 3 shelves

ELECTRICAL

- ▶ Safety switches (residual current devices)
- ▶ Direct wired smoke detectors
- ▶ Batten holders throughout
- ▶ 1 x Rear flood light
- ▶ Exhaust fans to areas with no openable window
- ▶ 1 x Double powerpoint to each room (refer to Electrical Plans)
- ▶ 1 x Television and phone point (refer to Electrical Plans)

HEATING

Flat Roof Design (Refer To Project Plans)

- ▶ Heating panels to all bedrooms and main living area

Pitched Roof Design (Refer To Project Plans)

- ▶ Gas ducted heating with thermostat (number of points and unit size are floorplan specific)

TOILETS

- ▶ Dual flush cisterns with Vitreous China pan
- ▶ Toilet roll holders

BATHROOM/ENSUITE

- ▶ Laminate cabinets and benchtops
- ▶ Vitreous china designer basins with chrome flick mixers
- ▶ White acrylic bath tub with chrome outlet and tap set with shower head and shower screen (floorplan specific)
- ▶ Polished edge mirrors (size width of vanities)
- ▶ Pre-formed shower base to all showers (refer to plans for size)
- ▶ Framed pivot door screen to all showers
- ▶ Wall mounted shower on rail with chrome mixer
- ▶ Double towel rail holder
- ▶ Designer pull handles

KITCHEN

- ▶ Australian made kitchen
- ▶ Laminate panels and doors and benchtops
- ▶ Feature shelves above bench
- ▶ Double end bowl stainless steel sink with chrome mixer
- ▶ Designer pull handles

APPLIANCES

- ▶ 600mm stainless steel Technika:
 - ▶ Built-in Oven
 - ▶ Gas Cooktop
 - ▶ Rangehood
 - ▶ Dishwasher

LAUNDRY

- ▶ 45L stainless steel tub with metal cabinet and chrome mixer

FLOOR COVERINGS

- ▶ Ceramic floor tiles or timber laminate (please refer to standard floorplan for locations)
- ▶ Ceramic floor tiles to bathroom, toilet, ensuite and laundry
- ▶ Carpet to remainder (refer to standard plans)

WALL TILES

Ceramic wall tiles to:

- ▶ Above kitchen bench including behind feature shelving
- ▶ 2000mm to shower walls
- ▶ Bath edge to floor and above bathtub

PAINT

- ▶ Premium 3 coat wall & 2 coat ceiling paint system
- ▶ High Gloss Enamel to all interior wood work and doors
- ▶ 2 coats to all exterior claddings

EXTERNAL

- ▶ Concrete driveway (as per plan)
- ▶ Full front and rear landscaping with plants, pebbles and mulch
- ▶ Fixed fencing to all boundaries to developers requirements (refer to plans)
- ▶ Letterbox
- ▶ Clothesline (All external works to builders discretion)

INCLUDED AT WILLIAMS WALK AT NO EXTRA CHARGE

- ☑ 20mm stone to kitchen, bathroom and ensuite
- ☑ Provide LED downlights to main living areas
- ☑ Garage Door Remote (x3) and Motor to Panel Lift

Interior styling at your fingertips

Your choice from two stunning colour schemes.

CONTEMPORARY LIVING AT WILLIAMS WALK

CONTEMPORARY LIVING BY NOSTRA

01

MODE COLOUR SCHEME

The Mode interior design scheme offers a neutral and earthy colour palette – designed to create a calm and relaxed space. Timber textures establish a unique and contemporary style, with warm and inviting undertones. The ‘Mode’ colour scheme becomes the perfect designer palette for any furniture and décor items for the home.

UPGRADE OPTIONS

MODE
Interior Design Scheme

Please refer to complete colour boards, inclusions and colour selection document for full details.

01

MODE COLOUR SCHEME

The Mode interior design scheme offers a neutral and earthy colour palette – designed to create a calm and relaxed space. Timber textures establish a unique and contemporary style, with warm and inviting undertones. The ‘Mode’ colour scheme becomes the perfect designer palette for any furniture and décor items for the home.

PREMIUM TEXTURES

STUNNING FINISHES

CONTEMPORARY LIVING BY NOSTRA

02

LUXE COLOUR SCHEME

With an array of muted and moody greys alongside white and natural timbers - The Luxe Interior design scheme creates a light, modern and timeless finish. Statement pieces such as; colourful artwork, ornaments and treasured possessions will assist in creating a unique and harmonious home design for years to come.

UPGRADE OPTIONS

LUXE
Interior Design Scheme

CONTEMPORARY LIVING AT WILLIAMS WALK

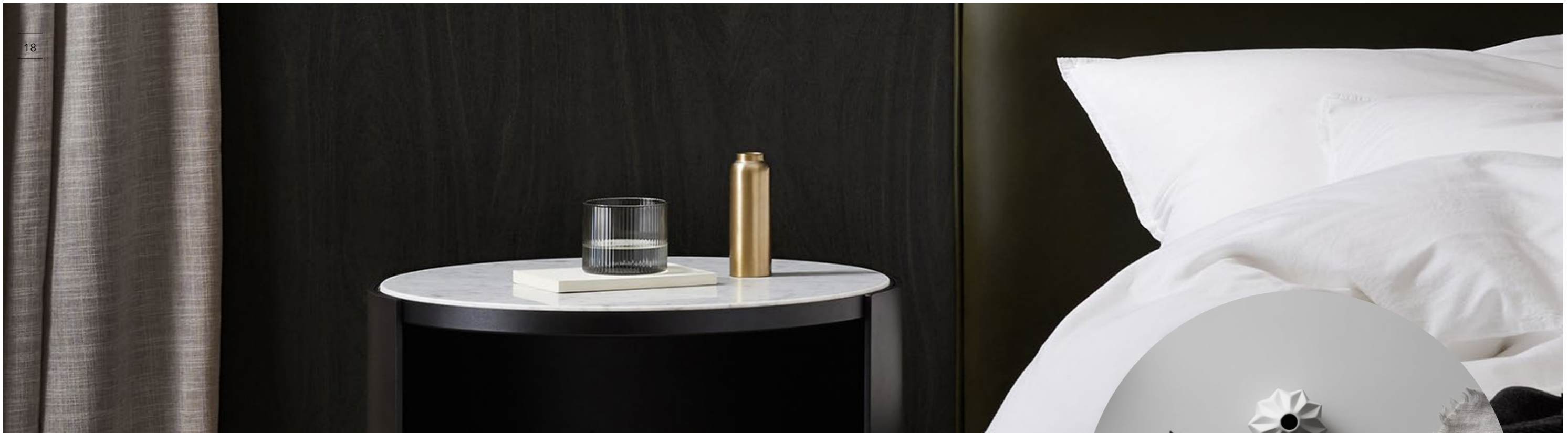

Hamptons

INTERIOR DESIGN SCHEME

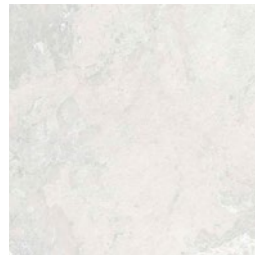

Floor Tiles
Maximo White Glazed Porcelain

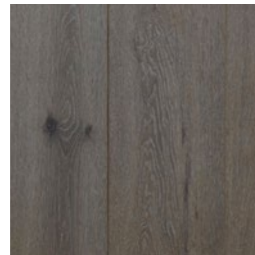

Timber Laminate Flooring
Aquatic Range - Abalone



Carpet
Balance - Barmah

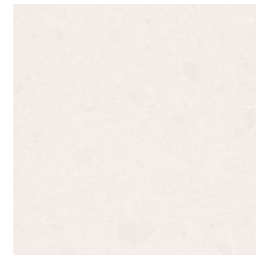

Stone Benchtops
Kitchen, Bathroom & Ensuite
20mm Edge - Organic White

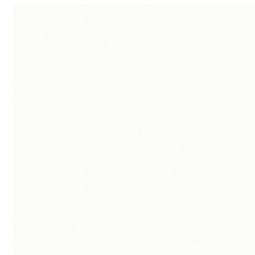

**Perimeter Base, Overhead & Fridge
Kitchen Cabinetry**
Calm White - Natural Finish

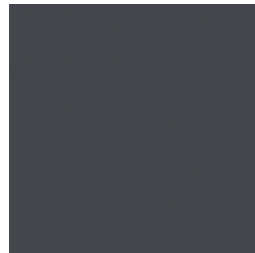

Kitchen Island Cabinetry
Charcoal - Natural Finish

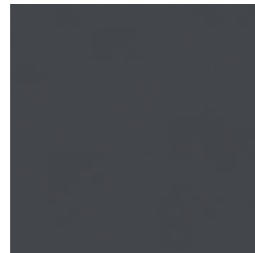

**Bathroom, Ensuite & Laundry (if
applicable) Base Cabinetry**
Charcoal - Natural Finish

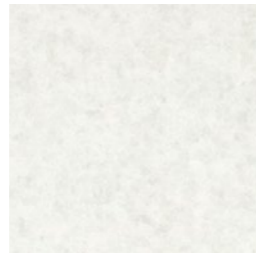

**Laundry Laminate Benchtop
(if applicable)**
Fresh Snow - Natural Finish

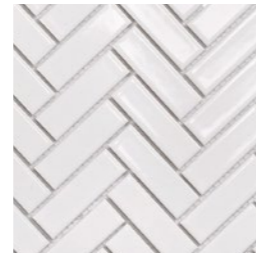

Kitchen Wall Tiles
Herringbone - White Gloss



Cabinetry Handles - Doors
Table Knob - Satin Nickel
(Includes Overhead Cabinetry)



Cabinetry Handles - Drawers
Crescent Finger Pull - Satin Nickel



Blinds
Earth - Chalk



Paint Colour
Builders White

03 UPGRADE

HAMPTONS COLOUR SCHEME

Finish your new Hamptons style townhome off in style with our stunning Hamptons interior design scheme.

Carefully crafted by Nostra's interior designer to ensure the interior of the home compliments the stunning Hamptons facade on show at Williams Walk.

All of this is on offer for only \$4,999

Why Nostra



24/7 Service through our dedicated online client portal

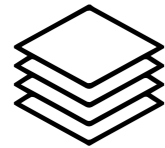

More timber in our frames and stronger slabs that exceed industry standard



A strong level of inclusions from the start



24/7 Emergency RACV home assist for the first 12 months after you move in for further peace of mind



High quality materials from trusted brands



All backed by a 25 year structural guarantee!

A Joint Partnership

NOSTRA

BUILDER
NOSTRA

Specialising in modern turn-key living, Nostra have been building outstanding homes throughout Melbourne suburbs since 2006. Nostra maintains a focus on creating affordable homes that exceed the industry standard using only quality products that stand the test of time. With a high level of standard finishes, Nostra's Contemporary Living options stand out for value without compromising on quality.



DEVELOPER
VILLAWOOD PROPERTIES

Villawood Properties has grown to become one of Australia's leading residential land developers.

With a proven track record in delivering innovative, community-focused developments, Villawood boasts a portfolio of over 50 completed residential projects.

From modest beginnings in 1989 developing small subdivisions in Bendigo, today Villawood Properties predominately concentrates on large scale master planned communities which incorporate a combination of mixed-use town centres, residents' clubs, educational facilities,

large display villages and the creation of high quality parks and open spaces. Villawood Properties understand there is much more to creating a living, breathing community than simply constructing a housing allotment, and are committed to going that extra mile to deliver vibrant communities right across Victoria.



WILLIAMS WALK

Rockbank • 3335

Contact Us

0487 888 035

williamswalk@villawoodproperties.com

PROUDLY DEVELOPED BY



NOSTRA

Disclaimer: House and land sold separately. Nostra Homes and Developments Pty Ltd acts as the builder of the home only. Buyers must enter into a separate contract with the land developer for the purchase and development of the land. Buyers should review the land and building contracts carefully, make their own inquiries and obtain independent advice before proceeding. Illustrations and information are intended to be indicative only and are believed to be correct at the time of publication. Nostra Homes and Developments Pty Ltd reserves the right to withdraw or alter any package at any time without notice at its absolute discretion. Estimated costs for the package are indicative only and other costs and fees are payable, including but not limited to: transfer/stamp duty, settlement/registration fees, legal/conveyancing fees, finance costs, site works, engagement of any consultants, approvals, connection for services and variations. All imagery on this brochure is for illustrative purposes only. Artist impression is for illustrative purposes only. Items depicted in these images that are excluded from the standard inclusions are included but not limited to pendant lighting, frameless shower screen, freestanding bath, downlights to bathroom, finger-pull cabinetry and fixtures. Final drawings are subject to developer and council approval; refer to the contract documentation for further details. Nostra Homes reserves the right to amend specification and price without notice. The First Home Owners Grant is a Government incentive and is subject to change. Nostra Homes and Developments Pty Ltd.